



# Test equipment insulation

PMW Engineering



Measuring devices for testing of insulation materials according to current standards and regulations

[WWW.pmw-engineering.com](http://WWW.pmw-engineering.com)

# Test equipment insulation

PMW Engineering manufactures and sells test equipment for insulation materials.

Testing of insulation materials delivers valuable information about the properties of the given material. And helps ensure that the material is in conformity with current standards and regulations.

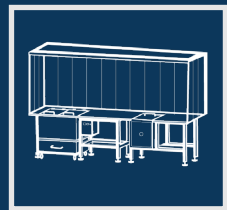
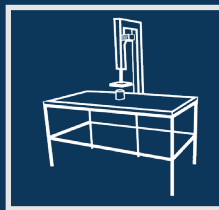
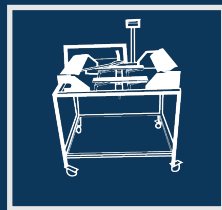

# PMW AnGa

## Squareness of insulation materials according to EN 824

AnGa is a measuring device for measuring the variation of squareness of insulation materials according to EN824 - Thermal insulation products for building applications. "Determination of Squareness".

### Features:

- Sturdy construction.
- Table mountable.
- Digital measuring instrument with electronic display readout.
- Adjustable perpendicular angle ledge. Factory calibrated at 90° degrees.
- Measuring and readout instrument is user friendly and programmable. Toggle between having perpendicularity deviations shown in mm/500mm or degrees.
- Digital measuring system with RS 232 and RS 485 for data storage.
- Angle standard settings: +/- 2.5° degrees.

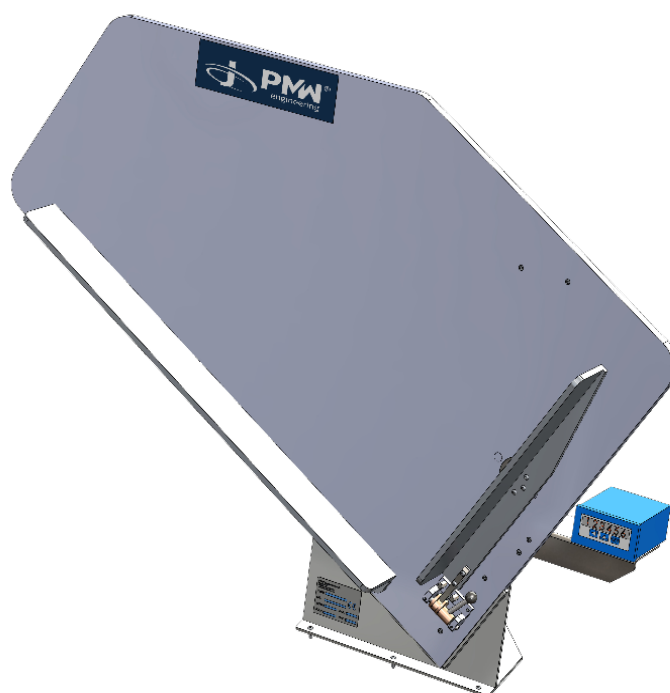

Technical data	
Height	720 mm
Width	300 mm
Length	1160 mm
Electrical connection	230V alt 115 V. (Specified with order)
Weight	approx. 28 kg

# PMW DefGa

## Deflection of insulation materials

The ends of the test specimen is fixed to a pair of bearing plates, placed parallel to each other at either end of the steel frame. With the test specimen held up by its ends to bearing plates able to freely rotate on their axis, a concentrated point load is created in the middle of the material, pulling it downward, unless the unloading mechanism is placed in top position.

### Features

- Constructed on an free standing steel frame, mounted on wheels for high mobility.
- 2 movable bearing plates consisting of aluminium, coated with pickled stainless steel.
- Unloading mechanism consisting of 2 aluminium plates with corrosion-resistant coating.
- Ball grip handle for easy operation of the equipment.
- Bearing plates suspended via rotating shafts, fitted with the finest ball bearings for minimal friction.
- Centre distance of 700mm and 800mm. Bearing plates can be moved forward or backward independently of each other.
- Highly sensitive measuring instruments consisting of a calibrated weighing arm and an arm with a magnetic sensor, fixed in parallel to a central axis.
- Polished plate mounted on the end of the weighing arm for frictionless contact with the test material during testing.
- Electronic display.
- RS 232 and RS 485 outputs for external data collection.

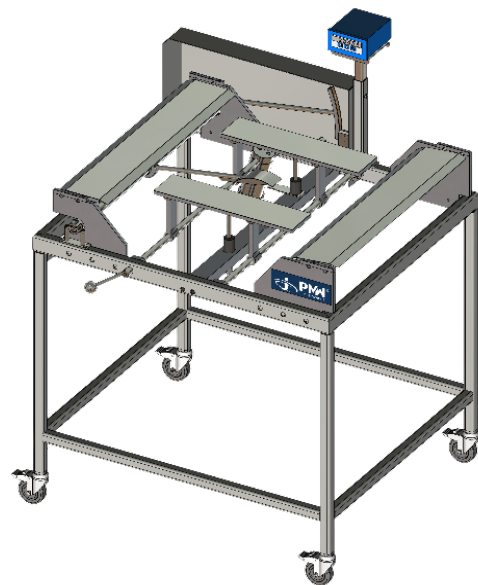

### Technical data

Height	1100 mm
Width	785 mm
Length	900 mm
Electrical connection	230V alt 115 V. (Specified with order)
Weight	approx. 56 kg

# PMW ThiGa

## Thickness Measurement Gauge - thickness of insulation materials

ThiGa is a measuring device for measuring thickness of insulation according to EN 823 - Thermal Insulation products.

The insulation material is placed under the magnetic gauge. Upon activation of a pneumatic foot pedal, the gauge puts a preselected level of pressure on the test material, whereby the gauge measures the resulting thickness of the material. Test results are shown on an electronic display. Once testing is complete, the foot pedal is activated again to release the test material.

### Features

- Strong construction. Frame of welded stainless steel.
- Foot pedal for safe and easy operation of the equipment.
- Digital measuring instrument with display readout and possibility of data collection via RS 232 and RS 485 outputs.
- Counterweights designed for pressures at 50 Pa. and 250 Pa.

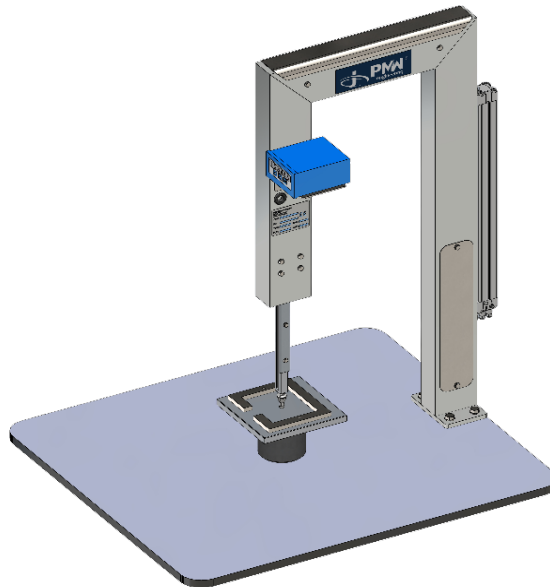

Technical data	
Height	720 mm
Width	300 mm
Electrical connection	230V alt 115 V. (Specified with order)
Air	approx. 28 kg
Weight	approx. 30 kg
Basis gauge block lenght	100 mm

# PMW WAB

## Water absorption bath for quality assurance test (QA) in the manufacture of insulation materials.

The PMW WAB is used for measuring the water absorbing capacity of insulation materials, in accordance with the European industry standard, EN 12087:2013 Thermal insulating products for building applications – “Determination of long term water absorption by immersion”.

The PMW WAB works by selecting a predetermined water level for the absorption bath, whereafter the test specimen are immersed in the water. As the water is gradually absorbed by the test specimen, the water regulation system will automatically add water to the bath, to ensure the desired water level is maintained and kept stable for the whole duration of the test.

### Feature

- Preselect desired water level and the water regulation system will automatically maintain it through the entire testing process.
- Baffle walls placed around the electronic level gauge, preventing sudden movements in the water from impacting its readings.
- With spirit levels and screw feet to adjust the height of the steel frame, making sure the baths are level is easy.
- Spring loaded pipes for preventing the test specimens from floating and keeping them immersed under water.
- Grooves placed in the bottoms of the baths for ensuring maximum water exposure to the test specimens.
- Construction with minimal space requirements due to the baths being placed on top of each other.
- Lower bath placed in a pull-out shelf, for easy and convenient operation.
- Inclined bottom for complete water discharge, when required.

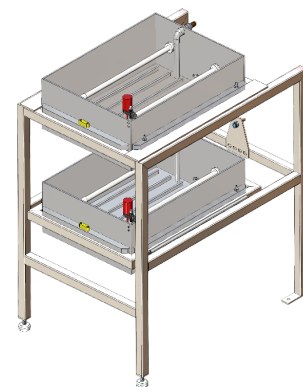

Technical data	
Height	1120 mm
Width	700 mm
Lenght	900 mm
Electrical connection	230V alt 115 V. (Specified with order)
Water intake	6 lit./min.
Weight	approx. 65 kg



# PMW WAX/DeWAX

## Delamination equipment - preparation for tensile strength measurement

The equipment includes a welded stainless frame with a stainless table surface, the wax bath with built-in heating elements is welded into the table surface.

### PMW WAX/DeWAX consists of the following elements:

- 8 pcs. 300 x 300mm aluminium plates anchor.
- 1 pc. handle to safely lift the aluminium sheets.
- Waxing table, with built-in melting bath for application of the aluminium sheets before the delamination test.
- De-waxing table, with built-in fan heater for melting wax off of the aluminium sheets after the completion of a delamination test.
- Waste tray for the collection of melted off wax.
- Electrical temperature control.
- Adjustable timer that allows for the unit to shut down automatically at a preset time.

## WAX

**Construction:** The Waxing table unit consists of a welded stainless frame (ASIS 304) with a stainless table surface. The Wax bath with built-in heating elements is welded into the table surface.

## DeWAX

**Construction:** The De-Waxing table unit consists of a welded stainless frame (ASIS 304) with a stainless table surface. The De-Wax unit is constructed with a pit for de-waxing up to 4 aluminum plates at one time. The pit is welded into the table surface and supplied with two lids for optimized friendliness.

A Leister HotAir unit is supplied for blowing hot air via special manufactured manifold that also operates as a holding bar for the aluminum plates when mounted on special brackets.

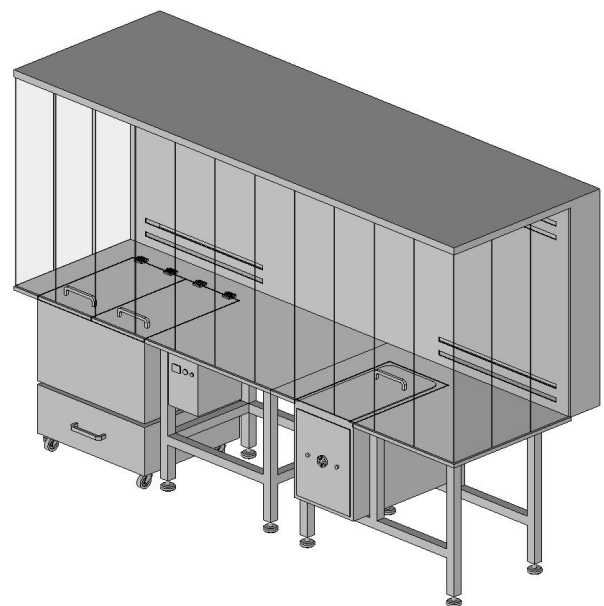



---

## Our companies

### Jesma Weighing Solutions

Helsingørvej 18  
DK-7100 Vejle  
Tel: +45 75 72 11 00  
@: Jesma@jesma.dk

### PMW Engineering

Helsingørvej 18  
DK-7100 Vejle  
Tel: +45 46 32 16 50  
@: info@pmw-engineering.com

### SEG Instrument

Florettgatan 33  
SE-254 67 Helsingborg  
Tel: +46 87 64 74 00  
@: info-seg@jesmagroup.com

---

 Part of Jesma Group

[www.pmw-engineering.com](http://www.pmw-engineering.com)